

Methods

A step-by-step guide for manufacturing a reliable and low-cost entomological dissection microvial for pinned specimens

André Silva Fernandes¹, Joab Cardoso Guedes¹, Tiago Kutter Krolow¹¹ Universidade Federal do Tocantins (UFT), Laboratório de Entomologia (LabEnt), Porto Nacional, TO, Brazil<https://zoobank.org/E5848196-29FB-4E88-A339-1F6A4B108DD4>Corresponding author: André Silva Fernandes (andresf@uft.edu.br)

Academic editor: Vinicius S. Ferreira | Received 20 May 2025 | Accepted 6 August 2025 | Published 10 September 2025

Abstract

Entomological collections face significant challenges in storing and preserving dissected structures of insects (especially the most delicate and tiny ones). For pinned specimens, few alternatives are available to keep dissected parts along with their source specimens, with pinnable microvials commonly used. However, world suppliers for these special microvials are scarce and their cost may reasonably impact the budget of less wealthy institutions. To provide a low-cost alternative, we designed a reliable entomological dissection microvial, based on materials easily found in most local office and laboratory equipment suppliers. Our microvials are based on two main items, Polypropylene (PP) microcentrifuge tubes and Ethylene Vinyl Acetate (EVA) hot-melt glue. Their manufacturing process is very simple and is described and illustrated in detail. The proposed microvials tend to have good ability for archiving, since the materials used for their main parts (PP and EVA) show good chemical adhesion and PP microcentrifuge tubes can safely contain most common preserving solutions for an indefinite time. Their endurance was tested under normal use conditions in our collection for the past five years and materials showed no degradation. Moreover, all components are classified as non-toxic and are safe for manipulation, storage and disposal by any educational or research facility. Finally, they fit into the category of sustainable solutions once they are long-lasting, reusable and can be manufactured from used microvials that would be discharged.

Key Words

Alternative methods, entomological collections, genitalia vials, microtubes, preserving, storage

Introduction

Zoological collections hold ex situ biological material of all kinds of animals. Their main purpose is to keep and guard faunal representatives and data for biodiversity knowledge and for scientific studies in a vast range of areas like public health (e.g. Hoffmaster et al. (2002)), agriculture (e.g. Davies et al. (1999)) and climate change (e.g. Parmesan et al. (1999)) (Suarez and Tsutsui 2003; Pyke and Ehrlich 2010; Paknia and Koch 2015). Zootaxonomy and zoosystematics are particularly dependent on zoological collections as sources of data on species morphology, diversity, distribution and for acquiring biological samples (Suarez

and Tsutsui 2003; Pyke and Ehrlich 2010). Therefore, proper storage and maintenance of specimens deposited in collections are crucial for preserving biological and historical heritage of living beings throughout time (Engel et al. 2021).

As the most diverse group of organisms on Earth, insects are unmatched in diversity of species, morphological traits and habits (Zhang 2011; Storck 2018); thus, entomological research often relies on surveying specimens from collections aiming for a wider and deeper look on a given taxon (Camargo et al. 2015). The vast majority of the entomological collections are maintained mainly through public funding, due the high costs involved and their non-profit purpose (Britz et al. 2020).

However, leaving collections maintenance programmes at the mercy of political-economical decisions may be problematic, especially in Global South countries which struggle frequently to maintain long term policies devoted to non-basic needs (Agenda 2030 2015; Magalhães 2024). Add to that the tariff and exchange rate issues when purchasing imported laboratorial supplies (most from EU and US) and you may rapidly face an unfeasible scenario for less wealthy countries and their institutions, to keep well-maintained biological collections (Quintans-Júnior et al. 2020). Yet, many countries considered as “megadiverse” fall into the aforementioned category, which amplifies issues related to the lack of adequate structure and resources for them to safeguard properly the vast entomological material coming from their native areas (Paknia et al. 2015).

Preserving the most delicate diagnostic structures of insects, such as mouthparts, appendages and genitalia, poses a challenge to entomological collections. If properly preserved, these parts can last for centuries, safeguarding important biological information. In the case of preserving insect genitalia, microvials with glycerine are widely used as an alternative to mounting on permanent slides or simply gluing them to small paper boards, as it allows for further manipulation of the preserved parts (Young and Beirne 1958; Gurney et al. 1964).

However, finding vials suitable for this purpose is not an easy task, as they need to be small (around 1.0 to 2.0 centimetres) and attachable to the specimen’s pin from which it was extracted. With this issue in mind, Gurney et al. (1964) presented all existing solutions and techniques available at the time involved in preserving insect genitalia in microvials. Later, Deitz (1979) proposed the use of very small glass vials with cork stoppers, despite Gurney et al. (1964) having already condemned this practice, as the cork tends to dry out and crack. Aiming to solve that, van Doesburg (1980) suggested manufacturing PVC tubes sealed with a silicone stopper derived from medical supplies, resulting in the first self-manufactured low-cost microvial. However, the resulting tube was too big for smaller specimens and acquiring the needed medical supplies is not practical for a typical entomologist. So far, all commercial alternatives for genitalia microvials are variations of these techniques and are still widely used in collections worldwide.

Although simple in design and not demanding expensive materials for production, these tubes are manufactured for a very small niche market and have a considerably high final price. We surveyed the purchase costs for entomological microvials from online stores of seven worldwide suppliers and reached an average cost of 27.5 US Dollars per 100 units (Table 1). The value may not seem absurd at first glance, but when scaled up to purchases around tens of thousands of units (ordinary numbers of pinned specimens preserved in many entomological collections), it can impact the budget of collections. Additionally, all these suppliers are physically located in

Europe (with one in Australia) (Table 1) which makes the acquisition even harder for collections located in the Global South.

Faced with these challenges on a daily basis, our staff at the Entomological Collection of the Federal University of Tocantins (CEUFT) is constantly looking for affordable, but adequate, solutions for preserving and maintaining specimens. Over the past five years, we have successfully used self-manufactured dissection microvials for pinned specimens, which remain in very good condition. Taking into account that similar resource limitations affect emerging collections worldwide, we present here a step-by-step guide for producing a low-cost entomological microvial for storage of the genitalia and other dissected structures, using materials readily available from local suppliers anywhere in the world.

Materials and methods

Material used

- A) Hot-melt glue gun (Fig. 1A).
- B) Ethylene Vinyl Acetate (EVA) hot-melt adhesive stick (Fig. 1B).
- C) 0.1 ml Polypropylene (PP) microcentrifuge tubes (Fig. 1C).
- D) Flat or round tipped tweezer (Fig. 1D).

The methodology implemented on manufacturing the microvials was developed, based on the study of the suppliers’ instructions for application of the material used, instructions found in Gurney et al. (1964) and trial and error method. Once consistent and adequate results were achieved, the technique developed was summarised in a Mounting instructions section along with a pictorial instruction chart (Fig. 2). Material quality and composition may vary depending on the supplier; thus, testing and adapting may be required for best results. A Tips and Recommendations section provides important considerations for avoiding most common problems while assembling and using the manufactured microvials. Cost survey (Table 1) was based on internet searches throughout all main international and local suppliers of entomological material we found. For image processing and drawings, we used Adobe Photoshop CC.

Results

An alternative entomological dissection microvial for pinned specimens

Our proposed entomological dissection microvial consists of a Microvial PP cap with an EVA pinnable head and a Microvial PP body (Figs 2, 3).

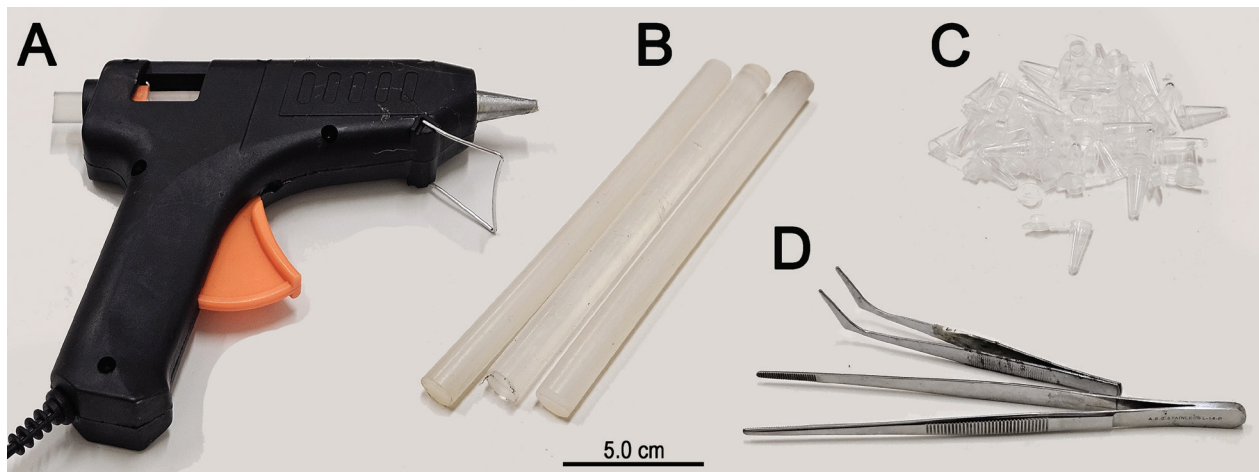

Figure 1. Equipment and materials used for assembling the dissection microvial. **A.** Hot-melt glue gun; **B.** Hot-melt glue sticks; **C.** Microtubes; **D.** Tweezers. See “material used” section for details on each item.

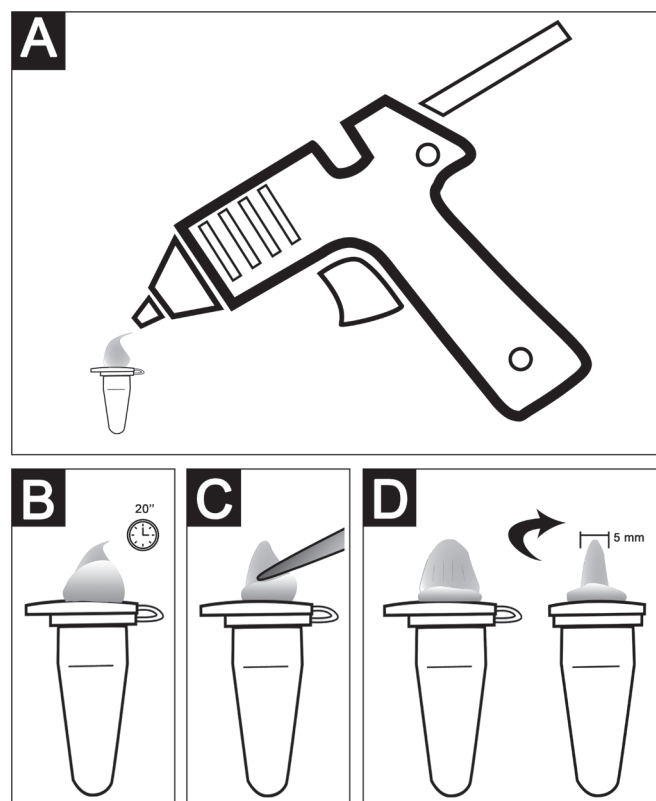

Figure 2. Pictorial instructions for assembling the dissection microvial. **A.** Applying the hot melted glue on the tube cap; **B.** Waiting for the glue to obtain moulding consistency; **C.** Moulding the droplet; **D.** Dissection microvial assembled. See “mounting” section for details on each step.

Mounting instructions

- A) Apply a small drop of melted EVA glue on the cap of the tube (Fig. 2A);
- B) Wait around 20 seconds until the melted glue droplet acquires mouldable consistency (Fig. 2B);
- C) Use a tweezer to mould the upper part of the droplet (Fig. 2C). Compress the droplet until its width reaches around 2.0 mm while also compressing it against the cap to form a wider base of contact with the cap (Fig. 2D).

Tips and recommendations

- A) Scrape or sand the tube cap to ensure best adhesion of EVA glue.
- B) Ensure that the tube’s cap is dry and clean prior to start.
- C) The glue must be very hot to secure adhesion with the tube’s cap. It will be hot enough if you wait approximately 30 seconds more after the glue starts to melt.
- D) It may help to use a touch of mineral oil or glycerol on the tweezer’s tips to avoid adhesion with de EVA glue while moulding.

- E) It requires a bit of practice until you start to standardise the size and shape of the EVA tip. However, it may be perfectly functional in various shapes and sizes, even not being aesthetically ideal.
- F) The recommended width of the EVA tip (2.0 mm) is based on our usage experience. A thinner EVA tip can crack more easily and may not hold the pin firmly enough, while an exaggerated wide tip may be too hard to be pierced and you may end up bending the pin trying so.
- G) While filling the tube with glycerine, use just enough fluid to safely cover the dissected structure, never fill the tube completely (Fig. 3A–C). Combine it with piercing the tube slightly angled downwards (Fig. 3B) and you will avoid the glycerine coming into contact with the cap, preventing the fluid from accidentally leaking from the tube. For details on techniques for proper usage of genitalia microvials, see Gurney et al. (1964).

Discussion

Usage

The idea for an alternative dissection microvial originated from the growing need for genitalia vials for pinned specimens deposited in CEUFT. However, pinnable microvials

can be used to store a variety of structures and even entire specimens, especially those that are too delicate to be dry-mounted, allowing them to be kept in entomological drawers. Since most insects whose genitalia were intended for mounting in our collection ranged from 1.0 to 20.0 mm, we fabricated only 0.1 ml units. In case larger specimens are prepared, microvials of larger volumes might be used to fabricate the genitalia vials to contain their dissected structures.

Endurance

After successfully assembling the microvials, we started conducting some tests seeking to improve its production for better resistance and usability. Despite no systematic testing being implemented, our trials did successfully track some sources of problems during assembling, which were addressed and resulted in increased production success, replicability and reliability. Most important tests aimed to check: the strength of adhesion of the EVA head with the PP microvial cap; the adequate length of the EVA head for practical and secure pinning; the bending/pulling resistance of the EVA head; the attachment and sealing of the microvial cap with its body. Tests' results were satisfactory for our daily use in the CEUFT and usability matched the commercial dissection microvials we have used previously. Knowledge acquired during these trials resulted in the tutorial described within the Materials and methods section.

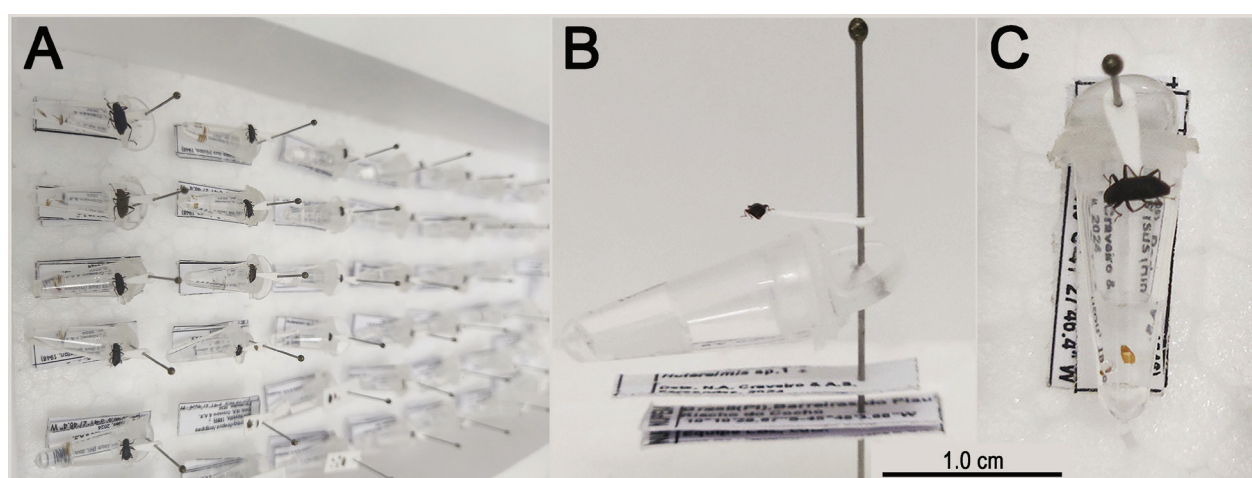

Figure 3. Entomological specimens at CEUFT mounted in pins with their genitalia stored in the dissection microvials. **A.** Box with specimens; **B.** Mounted microvial in lateral view; **C.** Mounted microvial in upper view.

Table 1. Comparative value of dissection micro-vials amongst several worldwide suppliers and the estimated cost of self-manufactured ones. P/100 = approximate price per 100 units; AP/100 = average price per 100 units amongst surveyed suppliers. Values are in US Dollars. The survey was made on 14 August 2024.

Supplier	Country	Store website	P/100	AP/100
Australian Entomological Supplies	Australia	entosupplies.com.au	50.00	27.50
OMNES Artes	Italy	omnesartes.com	30.00	
Entosphinx	Czechia	entosphinx.cz	30.00	
EntomoAlex-gr	Italy	entomoalex-gr.com	23.00	
Veldshop	Netherlands	veldshop.nl	13.00	
Paradox	Poland	insectnet.eu	19.00	
Self-manufactured	-	-	2.50	-

Production hazards

Polypropylene is widely used in various commercial products, including domiciliary goods and food packing. Tubes and vials made of this polymer are considered non-toxic and leave minimal residuals if used according to suppliers' recommendations (AMA 2025).

Hot melt EVA glue is a formaldehyde-free adhesive and is also implemented in a variety of applications, from home to industrial. Moreover, it can be used indoors and does not demand personal protective equipment (Zhang et al. 2023). Special care must be taken while handling the hot-melt glue gun; like any other electric device, it has to be used properly to avoid risk of electrocution. Additionally, the hot metal tip, at peak temperature, may harm the user if not handled carefully.

Archiving ability

Core components of polypropylene microtubes and hot-melt EVA glue, meaning PP and EVA, are amongst the most used and reliable materials for professional application in many segments, including museums and collections logistics (Tétreault 1993). The ability for archiving of our dissection microvials tends not to be a problem once combination of EVA and PP have good adhesion (if jointed properly) and PP vials can store solutions, based on most common conserving mediums (e.g. ethanol, formaldehyde, glycerol, mineral oil) for indefinite time in standard laboratory conditions (Weib and Pruszkowski 2013).

Sustainability

Besides reducing costs, producing your own laboratory supplies may help reduce excessive acquisition of consumables, once you can produce the supplies in quantities that are really going to be used. For assembling our dissection microvials, we acquired brand new microtubes; however, there might be no practical impediment for using already used ones. In this case, just make sure they are cleaned and free from any contaminant that may harm the structures to be stored or the personnel handling the material. The dissection microvials can also be reused, so in case the specimens or structures stored are discharged or transferred to other mediums, the microvial can be used for storing new ones. Additionally, the microvials are easily repairable (e.g. in case the EVA head breaks or detaches from the tube cap, a new one can be rapidly provided). That being said, we believe the dissection microvials proposed here generate minimum long-term plastic waste and, despite its components making part of the plastic industry chain, they are as friendly as possible for the environment (Urbina et al. 2015).

Conclusions

The budget of many biological collections is dependent on non-permanent funding, which may shrink due to political and economic decisions at any time, even in scientifically well-structured countries like the USA (Dalton 2003; Gropp 2003). Cost-effective methodological alternatives may represent a buffer for scientific institutions during financial crises. In some cases, they may even permanently replace more expensive commercial supplies. If manufactured properly, the dissection microvials proposed here should last as long as any of the commercially available versions, since most share similar composition to the homemade ones. They can also be rapidly made by researchers and students in their labs or at home, without waiting for product delivery. More importantly, the estimated cost of production is around 2.50 US Dollars per 100 units, corresponding to 1/12th the average price of commercial ones (Table 1). Disadvantages of using these vials include the time needed for manufacturing the microvials at scale, especially for larger collections or projects. Aesthetics traits (e.g. branding, uniformity, presentation) may also play an important role on the decision of which microvial to purchase. Institutions may prefer to keep standardised supplies in their collections and continue to use items they already rely on, even at a higher cost.

Acknowledgements

Authors thank UFT for the support and the Brazilian Innovation Agency (FINEP) project “Análise e Mapeamento da Biodiversidade e Recursos Hídricos do Estado do Tocantins” (process number 01.18.0077.00) for financing equipment and infrastructure. JCG thanks the Coordenação de Aperfeiçoamento de pessoal de Nível Superior (CAPES) and the Fundação de Amparo à Pesquisa do Estado do Tocantins (FAPT) for the scholarship grant (n. 88887.6292119/2021-00). TKK thanks the Conselho Nacional de Desenvolvimento Científico e Tecnológico (CNPq) for the scholarship grant (n. 310214/2021-1).

References

- Agenda 2030 (2015) Transforming our world: The 2030 agenda for sustainable development. <https://sdgs.un.org/2030agenda>
- Britz R, Hundsdoerfer A, Fritz U (2020) Funding, training, permits—the three big challenges of taxonomy. *Megataxa* 1(1): 49–52. <https://doi.org/10.11646/megataxa.1.1.10>
- Camargo AJA, De Oliveira CM, Frizzas MR, Sonoda KC, Corrêa D (2015) Coleções entomológicas: legislação brasileira, coleta, curadoria e taxonomias para as principais ordens. EMBRAPA, Brasília, 118 pp.
- Dalton R (2003) Natural history collections in crisis as funding is slashed. *Nature* 423: 575. <https://doi.org/10.1038/423575a>

- Davies N, Villablanca FX, Roderick GK (1999) Bioinvasions of the medfly *Ceratitis capitata*: Source estimation using DNA sequences at multiple intron loci. *Genetics* 153: 351–360. <https://doi.org/10.1093/genetics/153.1.351>
- Deitz LL (1979) Curatorial note on genitalia vials. *New Zealand Entomologist* 7(1): 10–11. <https://doi.org/10.1080/00779962.1979.9722322>
- Engel MS, Ceriaco LM, Daniel GM, Dellapé PM, Löbl I, Marinov M, Reis RE, Young MT, Dubois A, Agarwal I, Lehmann PA, Alvarado M, Alvarez A, Andreone F, Araujo-Vieira K, Ascher JS, Baêta D, Baldo D, Bandeira SA, Barden P, Barrasso DA, Bendifallah L, Bockmann FA, Böhme W, Borkent A, Brandão CRF, Busack SD, Bybee SM, Channing A, Chatzimanolis S, Christenhusz MJM, Crisci JV, D'elía G, Da Costa LM, Davis SR, De Lucena CAS, Deuve T, Elizalde SF, Faivovich J, Farooq H, Ferguson AW, Gippoliti S, Gonçalves FMP, Gonzalez VH, Greenbaum E, Hinojosa-Díaz IA, Ineich I, Jiang J, Kahono S, Kury AB, Lucinda PHF, Lynch JD, Malécot V, Marques MP, Marris JWM, Mckellar RC, Mendes LF, Nihei SS, Nishikawa K, Ohler A, Orrico VGD, Ota H, Paiva J, Parrinha D, Pauwels OSG, Pereyra MO, Pestana LB, Pinheiro PDP, Prendini L, Prokop J, Rasmussen C, Rödel M, Rodrigues MT, Rodríguez SM, Salatnaya H, Sampaio I, Sánchez-García A, Shebl MA, Santos BS, Solórzano-Kraemer MM, Sousa ACA, Stoev P, Teta P, Trape J, Santos CV, Vasudevan K, Vink CJ, Vogel G, Wagner P, Wappler T, Ware JL, Wedmann S, Zacharie CK (2021) The taxonomic impediment: a shortage of taxonomists, not the lack of technical approaches. *Zoological Journal of the Linnean Society* 193(2): 381–387. <https://doi.org/10.1093/zoolinnean/zlab072>
- Gropp RE (2003) Are university natural science collections going extinct? *BioScience* 53(6): 550. [https://doi.org/10.1641/0006-3568\(2003\)053\[0550:AUNSCG\]2.0.CO;2](https://doi.org/10.1641/0006-3568(2003)053[0550:AUNSCG]2.0.CO;2)
- Gurney AB, Kramer JP, Steyskal GC (1964) Some techniques for the preparation, study, and storage in microvials of insect genitalia. *Annals of the Entomological Society of America* 57(2): 240–242. <https://doi.org/10.1093/aesa/57.2.240>
- Hoffmaster AR, Fitzgerald CC, Ribot E, Mayer LW, Popovic T (2002) Molecular subtyping of *Bacillus anthracis* and the 2001 bioterrorism-associated anthrax outbreak, United States. *Emerging Infectious Diseases* 8: 1111–1116. <https://doi.org/10.3201/eid0810.020394>
- National Center for Biotechnology Information (2025) National Center for Biotechnology Information: PubChem Compound Summary for Polypropylene. <https://pubchem.ncbi.nlm.nih.gov/compound/Polypropylene>
- Paknia O, Koch A (2015) Lack of well-maintained natural history collections and taxonomists in megadiverse developing countries hampers global biodiversity exploration. *Organisms Diversity & Evolution* 15(3): 619–629. <https://doi.org/10.1007/s13127-015-0202-1>
- Parmesan C, Ryrholm N, Stefanescu C, Hill JK, Thomas CD, Descimon H, Huntley B, Kaila L, Kullberg J, Tammaru T, Tennent WJ, Thomas JA, Warren M (1999) Poleward shifts in geographical ranges of butterfly species associated with regional warming. *Nature* 399: 579–583. <https://doi.org/10.1038/21181>
- Pyke GH, Ehrlich PR (2010) Biological collections and ecological/environmental research: a review, some observations and a look to the future. *Biological Reviews* 85(2): 247–266. <https://doi.org/10.1111/j.1469-185X.2009.00098.x>
- Quintans-Júnior LJ, Albuquerque GR, Oliveira SC, Silva RR (2020) Brazil's research budget: endless setbacks. *EXCLI Journal* 19: 1322–1324. <http://dx.doi.org/10.17179/excli2020-2887>
- Stork NE (2018) How many species of insects and other terrestrial arthropods are there on Earth? *Annual Review of Entomology* 63(1): 31–45. <https://doi.org/10.1146/annurev-ento-020117-043348>
- Suarez AV, Tsutsui ND (2003) The value of museum collections for research and society. *BioScience* 54(1): 66–74. [https://doi.org/10.1641/0006-3568\(2004\)054\[0066:TVOMCF\]2.0.CO;2](https://doi.org/10.1641/0006-3568(2004)054[0066:TVOMCF]2.0.CO;2)
- Tétrault J (1993) Guidelines for Selecting Materials for Exhibit, Storage and Transportation. Canadian Conservation Institute, Ottawa.
- Teixeira BM (2024) Room to grow and the right to say no: Theorizing the liberatory power of peace in the Global South. *Geopolitics* 29(5): 1–33. <https://doi.org/10.1080/14650045.2023.2286287>
- Urbina M, Watts A, Reardon E (2015) Labs should cut plastic waste too. *Nature* 528: 479. <https://doi.org/10.1038/528479c>
- van Doesburg PH (1980) Genitalia vials from PVC tube. *Entomologische Berichten* 40(12): 177–178.
- Weib N, Pruszkowski S (2013) The best material for original Eppendorf Tubes and Plates: Properties and chemical resistance of polypropylene. Application Note 056.
- Young DA, Beirne BP (1958) A taxonomic revision of the leafhopper genus *Flexamia* and a new related genus. United States Department of Agriculture Technical Bulletin 1173: 1–53.
- Zhang ZQ (2011) Animal biodiversity: An outline of higher-level classification and survey of taxonomic richness. *Zootaxa* 3148(1): 7–12. <https://doi.org/10.11646/zootaxa.3148.1.3>
- Zhang Y, He Y, Yu J, Lu Y, Zhang X, Fang L (2023) Fabrication and characterization of EVA resins as adhesives in plywood. *Polymers* 15: 1834. <https://doi.org/10.3390/polym15081834>